

Face Milling

# MFB288

Arbor( Without Shim)

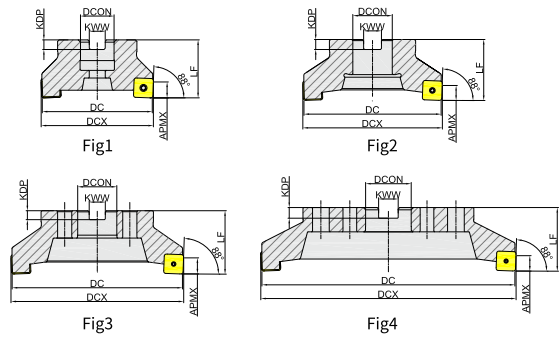

Ordering Code	Dia-meter	Teeth	Dimension(mm)							APMX	Suitable for	Shim	Coolant	Shape	Stock
			DC	DCX	DCON	LF	KWW	KDP							
MFB288050R04A22SN12	50	4	50	51	22	40	10.4	6.3	7	SNE(M)U1206ZNEN	×	✓	Fig1	●	
MFB288063R05A22SN12	63	5	63	64	22	40	10.4	6.3	7	SNE(M)U1206ZNEN	×	✓	Fig1	●	
MFB288063L05A22SN12	63	5	63	64	22	40	10.4	6.3	7	SNE(M)U1206ZNEN	×	✓	Fig1	●	
MFB288063R06A22SN12	63	6	63	64	22	40	10.4	6.3	7	SNE(M)U1206ZNEN	×	✓	Fig1	●	
MFB288080R05A27SN12	80	5	80	81	27	50	12.4	7	7	SNE(M)U1206ZNEN	×	✓	Fig1	●	
MFB288080R07A27SN12	80	7	80	81	27	50	12.4	7	7	SNE(M)U1206ZNEN	×	✓	Fig1	●	
MFB288080L07A27SN12	80	7	80	81	27	50	12.4	7	7	SNE(M)U1206ZNEN	×	✓	Fig1	●	
MFB288100R08B32SN12	100	8	100	101	32	50	14.4	8	7	SNE(M)U1206ZNEN	×	×	Fig2	●	
MFB288125R10B40SN12	125	10	125	126	40	63	16.4	9	7	SNE(M)U1206ZNEN	×	×	Fig2	●	
MFB288160R12C40SN12	160	12	160	161	40	63	16.4	9	7	SNE(M)U1206ZNEN	×	×	Fig3	●	
MFB288200R14C60SN12	200	14	200	201	60	63	25.7	14	7	SNE(M)U1206ZNEN	×	×	Fig3	●	
MFB288250R16C60SN12	250	16	250	251	60	63	25.7	14	7	SNE(M)U1206ZNEN	×	×	Fig3	○	
MFB288315R20D60SN12	315	20	315	316	60	80	25.7	14	7	SNE(M)U1206ZNEN	×	×	Fig4	○	

● Stock ○ Available Upon Order