

Face Milling

MFB275

Arbor(Without Shim)

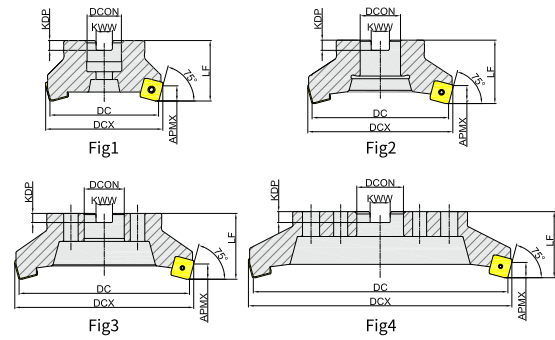

Ordering Code	Dia-meter	Teeth	Dimension(mm)							APMX	Suitable for	Shim Coolant Shape		Stock
			DC	DCX	DCON	LF	KWW	KDP	×			✓		
MFB275050R04A22SN12	50	4	50	55	22	40	10.4	6.3	5	SNE(M)U1206ENEN	×	✓	Fig1	●
MFB275063R05A22SN12	63	5	63	68	22	40	10.4	6.3	5	SNE(M)U1206ENEN	×	✓	Fig1	●
MFB275063R06A22SN12	63	6	63	68	22	40	10.4	6.3	5	SNE(M)U1206ENEN	×	✓	Fig1	●
MFB275080R07A27SN12	80	7	80	85	27	50	12.4	7	5	SNE(M)U1206ENEN	×	✓	Fig1	●
MFB275100R08B32SN12	100	8	100	105	32	50	14.4	8	5	SNE(M)U1206ENEN	×	×	Fig2	●
MFB275125R10B40SN12	125	10	125	130	40	63	16.4	9	5	SNE(M)U1206ENEN	×	×	Fig2	●
MFB275160R12C40SN12	160	12	160	165	40	63	16.4	9	5	SNE(M)U1206ENEN	×	×	Fig3	●
MFB275200R14C60SN12	200	14	200	205	60	63	25.7	14	5	SNE(M)U1206ENEN	×	×	Fig3	●
MFB275250R16C60SN12	250	16	250	255	60	63	25.7	14	5	SNE(M)U1206ENEN	×	×	Fig3	○
MFB275315R20D60SN12	315	20	315	320	60	80	25.7	14	5	SNE(M)U1206ENEN	×	×	Fig4	○

● Stock ○ Available Upon Order

Spare Parts

Part Name		Inserts Screw	Insert Screw Wrench	
Inserts	Shape			
	Specification Ordering Code	SI60M5.0X14.0-07010I SI60M050140-07010IB	TI20P TI20PB	TI20T TI20TB