

Face Milling

# MFB145

Arbor(with Shim)

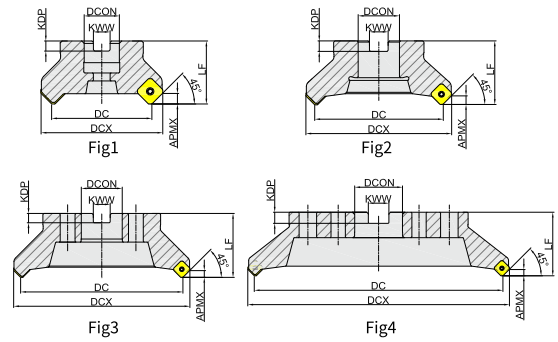

Sparse Pitch

Ordering Code	Dia-meter	Teeth	Dimension(mm)							APMX	Suitable for	Shim	Coolant	Shape	Stock
			DC	DCX	DCON	LF	KWW	KDP							
MFB145050R03A22SN12	50	3	50	63.5	22	40	10.4	6.3	3	SNE(M)U1206AN*N	✓	✓	Fig1	●	
MFB145063R04A22SN12	63	4	63	76.5	22	40	10.4	6.3	3	SNE(M)U1206AN*N	✓	✓	Fig1	●	
MFB145080R05A27SN12	80	5	80	93.5	27	50	12.4	7	3	SNE(M)U1206AN*N	✓	✓	Fig1	●	
MFB145080L05A27SN12	80	5	80	93.5	27	50	12.4	7	3	SNE(M)U1206AN*N	✓	✓	Fig1	●	
MFB145100R06B32SN12	100	6	100	113.5	32	50	14.4	8	3	SNE(M)U1206AN*N	✓	×	Fig2	●	
MFB145125R07B40SN12	125	7	125	138.5	40	63	16.4	9	3	SNE(M)U1206AN*N	✓	×	Fig2	●	
MFB145160R08C40SN12	160	8	160	173.5	40	63	16.4	9	3	SNE(M)U1206AN*N	✓	×	Fig3	●	
MFB145200R10C60SN12	200	10	200	213.5	60	63	25.7	14	3	SNE(M)U1206AN*N	✓	×	Fig3	●	
MFB145250R12C60SN12	250	12	250	263.5	60	63	25.7	14	3	SNE(M)U1206AN*N	✓	×	Fig3	○	
MFB145315R15D60SN12	315	15	315	328.5	60	80	25.7	14	3	SNE(M)U1206AN*N	✓	×	Fig4	○	

● Stock ○ Available Upon Order

Dense Pitch

Ordering Code	Dia-meter	Teeth	Dimension(mm)							APMX	Suitable for	Shim	Coolant	Shape	Stock
			DC	DCX	DCON	LF	KWW	KDP							
MFB145050R04A22SN12	50	4	50	63.5	22	40	10.4	6.3	3	SNE(M)U1206AN*N	✓	✓	Fig1	●	
MFB145050L04A22SN12	50	4	50	63.5	22	40	10.4	6.3	3	SNE(M)U1206AN*N	✓	✓	Fig1	●	
MFB145063R05A22SN12	63	5	63	76.5	22	40	10.4	6.3	3	SNE(M)U1206AN*N	✓	✓	Fig1	●	
MFB145080R07A27SN12	80	7	80	93.5	27	50	12.4	7	3	SNE(M)U1206AN*N	✓	✓	Fig1	●	
MFB145080L08A27SN12	80	8	80	93.5	27	50	12.4	7	3	SNE(M)U1206AN*N	✓	✓	Fig1	●	
MFB145100R08B32SN12	100	8	100	113.5	32	50	14.4	8	3	SNE(M)U1206AN*N	✓	×	Fig2	●	
MFB145125R10B40SN12	125	10	125	138.5	40	63	16.4	9	3	SNE(M)U1206AN*N	✓	×	Fig2	●	
MFB145160R12C40SN12	160	12	160	173.5	40	63	16.4	9	3	SNE(M)U1206AN*N	✓	×	Fig3	●	
MFB145160L12C40SN12	160	12	160	173.5	40	63	16.4	9	3	SNE(M)U1206AN*N	✓	×	Fig3	●	
MFB145200R14C60SN12	200	14	200	213.5	60	63	25.7	14	3	SNE(M)U1206AN*N	✓	×	Fig3	●	
MFB145200L14C60SN12	200	14	200	213.5	60	63	25.7	14	3	SNE(M)U1206AN*N	✓	×	Fig3	●	
MFB145250R16C60SN12	250	16	250	263.5	60	63	25.7	14	3	SNE(M)U1206AN*N	✓	×	Fig3	○	
MFB145315R20D60SN12	315	20	315	328.5	60	80	25.7	14	3	SNE(M)U1206AN*N	✓	×	Fig4	○	

● Stock ○ Available Upon Order

Face Milling

# MFB145

Arbor(with Shim)

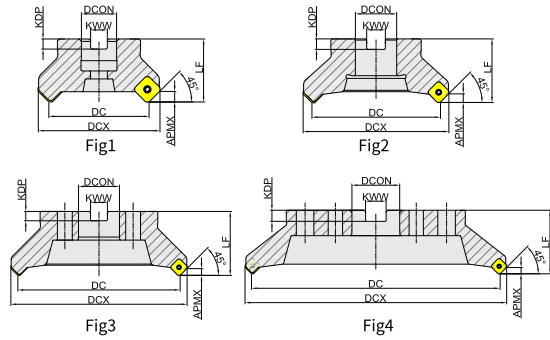

Extral Dense Teeth

Ordering Code	Dia-meter	Teeth	Dimension(mm)							APMX	Suitable for	Shim	Coolant	Shape	Stock
			DC	DCX	DCON	LF	KWW	KDP							
MFB145050R05A22SN12	50	5	50	63.5	22	40	10.4	6.3	3	SNE(M)U1206AN*N	✓	✓	Fig1	●	
MFB145063R06A22SN12	63	6	63	76.5	22	40	10.4	6.3	3	SNE(M)U1206AN*N	✓	✓	Fig1	●	
MFB145080R08A27SN12	80	8	80	93.5	27	50	12.4	7	3	SNE(M)U1206AN*N	✓	✓	Fig1	●	
MFB145100R10B32SN12	100	10	100	113.5	32	50	14.4	8	3	SNE(M)U1206AN*N	✓	×	Fig2	●	
MFB145125R12B40SN12	125	12	125	138.5	40	63	16.4	9	3	SNE(M)U1206AN*N	✓	×	Fig2	●	
MFB145160R15C40SN12	160	15	160	173.5	40	63	16.4	9	3	SNE(M)U1206AN*N	✓	×	Fig3	●	
MFB145200R18C60SN12	200	18	200	213.5	60	63	25.7	14	3	SNE(M)U1206AN*N	✓	×	Fig3	●	
MFB145200L18C60SN12	200	18	200	213.5	60	63	25.7	14	3	SNE(M)U1206AN*N	✓	×	Fig3	●	
MFB145250R21C60SN12	250	21	250	263.5	60	63	25.7	14	3	SNE(M)U1206AN*N	✓	×	Fig3	○	
MFB145315R24D60SN12	315	24	315	328.5	60	80	25.7	14	3	SNE(M)U1206AN*N	✓	×	Fig4	○	

● Stock ○ Available Upon Order

## Spare Parts

Part Name		Shim	Shim Screw	Wrench	Inserts Screw	Insert Screw Wrench	
Inserts	Shape						
	Specif-ication	DSN1206M	SSAM6.0X7.5F	TH40L	SI60M4.0X15.8-07108	TT15P	TT15T
SNE(M)U1206	Ordering Code	H0K30SSN12	SSAM060075B	TH40LB	SI60M040158-07108B	TT15PB	TT15TB